

[CONTRIBUTION FROM THE KENT CHEMICAL LABORATORY OF THE UNIVERSITY OF CHICAGO AND THE CHEMICAL LABORATORIES OF THE PENNSYLVANIA STATE COLLEGE]

AN IMPROVED, CONTINUOUS-READING HYDROGEN-ION METER

By KENNETH H. GOODE

RECEIVED APRIL 27, 1925

PUBLISHED OCTOBER 6, 1925

A continuous-reading voltmeter for indicating electrode potentials in various types of cells without drawing sufficient current from the cell to disturb the equilibrium is desirable for many electrochemical investigations and measurements, and is particularly needed in work on hydrogen-ion concentrations. An electrotitration apparatus has been described¹ which renders unnecessary the tapping key and balance of potentials ordinarily required, and which yields a continuous indication of the potential between a hydrogen and a calomel electrode without drawing an appreciable current from this source. This apparatus uses a galvanometer and readings are made with a telescope and scale.

In order to avoid the use of a telescope and scale, which is inconvenient for classroom demonstration or for routine titration work, it has been found possible to make use of the amplifying characteristics of the vacuum tube

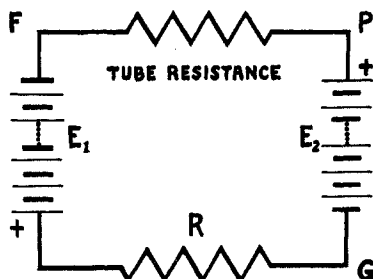

Fig. 1.

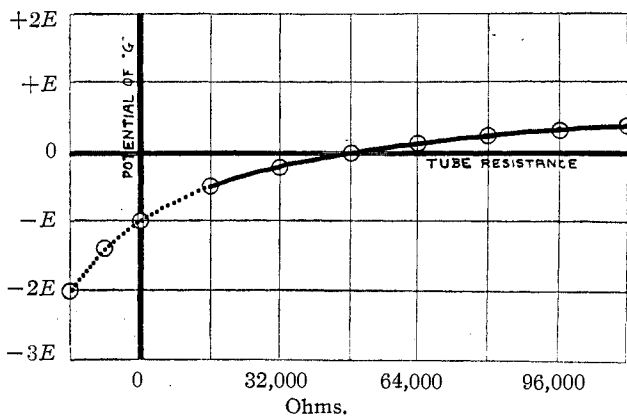

Fig. 2.

to magnify the currents to such a value that they can be easily measured with a milliammeter. This meter can be calibrated directly in Sørensen units, and as the action of this device is also continuous, any changes

¹ Goode, THIS JOURNAL, 44, 26 (1922).

in the hydrogen-ion concentration in the titration cell may readily be followed on the meter without making any adjustments of the apparatus.

The meter which was selected as the most practical was a Weston (Model 280) portable milliammeter, which has a range of 0-3 milliamperes, with a 60-line scale. Since the current ($I_p - I_0$) which is to be amplified varies from 12×10^{-5} amperes to zero, it will be seen that an amplification of about 25 times is necessary to give currents ranging from 3×10^{-3}

to zero. Such an amplification can be easily secured by using two vacuum-tube amplifiers, making a total of three in the apparatus.

The tubes used were Type UV199 Radiotrons which were selected because, although electrically practically identical with the UV201 tubes, the filament current consumption is very low, three of these tubes

together consuming from 0.18 to 0.20 ampere. The filaments may thus be lighted by a battery of three dry cells, or a small 4-volt storage battery. The grid current of these tubes becomes too small to measure with a galvanometer, at a potential of +0.3 volt (with respect to the negative end of the filament); at all potentials more negative than this, the grid currents are entirely negligible.

In order to amplify the plate current of the first tube, it is necessary to have the grid potential of each tube affected in some way by the variations in plate current of the preceding tube. For this purpose resistances are used,² each of which has a value approximately equal to the internal plate-to-filament resistance of the tubes. A convenient and satisfactory resistance having a value of 48,000 ohms can be obtained,³ and two of these were used.

The tubes and resistances are connected in a circuit, the essential parts

² Transformers are ordinarily used in amplifiers, but cannot be used in this case because we wish to amplify *direct currents*.

³ These resistances are used in telephone systems, and can be obtained either at a telephone supply store or a radio store. The resistances of the two used were actually 48,000 and 47,750 ohms, respectively.

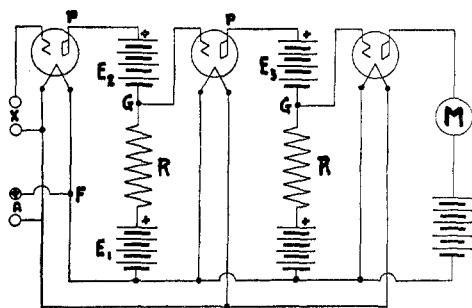

Fig. 3.

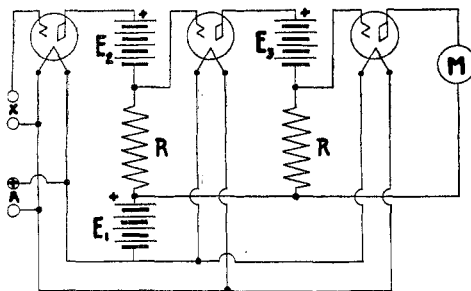

Fig. 4.

of which are shown in Fig. 1. It will be seen that if $E_1 = E_2$, and the resistance of the tube is equal to the external resistance R , the potential of the point G with respect to the point F is zero. Changing the tube resistance from 16,000 to 240,000 ohms (corresponding to plate currents from 3 to 0.2 milliamperes) produces changes in the potential of G with respect to F which lie along the fairly straight asymptotic portion of an hyperbola (Fig. 2). This potential thus bears nearly a linear relation to the tube resistance, which in turn (between the limits given above) is an almost linear function of the potential of its grid. If the point G is then connected to the grid of the succeeding tube, the plate current of each tube will bear a nearly linear relation to the potential X of the grid of the first tube. It is for this reason that the meter in the plate circuit of the last tube, if calibrated directly in Sørensen units will yield a nearly uniform scale. The wiring diagram of a succession of three tubes, arranged to make use of the principle of Fig. 1, is shown in Fig. 3. This calls for five batteries, each of about 50 volts. Two of these may be eliminated by simplifying the circuit to the form shown in Fig. 4, which was the circuit actually used.

The curve of Fig. 2 holds good only when $E_1 = E_2$; if

these potentials are not the same, the curve is shifted and the potential of the point G (with respect to F) can be changed to any convenient value by adjusting these potentials. By this means we can produce practically any kind of calibration curve, plotting the current through the meter against the potential of the first grid. Fig. 5 shows the changes produced by varying the potentials of the three batteries, and Fig. 6 shows how a slight ad-

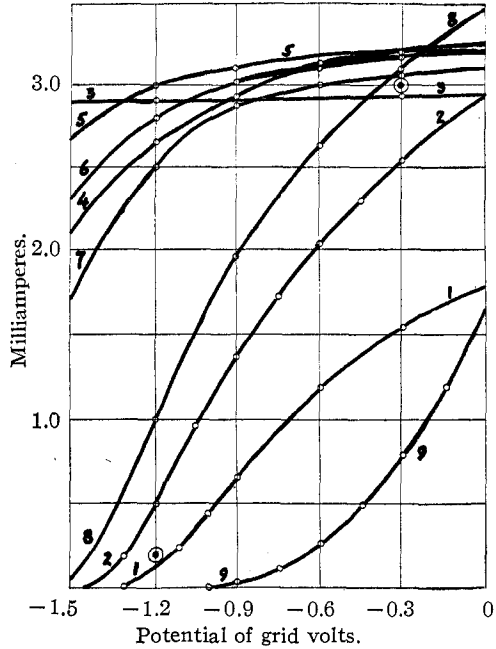

Fig. 5.—Filament current = 0.18 amp.

Curve	Battery voltages		
	E_1	E_2	E_3
1	16	33	33
2	33	33	39
3	33	56	57
4	53	56	57
5	55	56	57
6	61	55	57
7	68	56	57
8	68	47	53
9	68	47	47

justment of the filament current⁴ helps to secure a curve of the form desired. For electrotitration a straight line passing through the two points indicated by circles in Figs. 5 and 6 is the ideal calibration curve. Actually a curve resembling (12) is perfectly satisfactory, yielding a nearly uniform scale on the meter.

Although it is somewhat difficult to adjust the apparatus in the first place, once adjusted it will remain the same almost indefinitely, provided

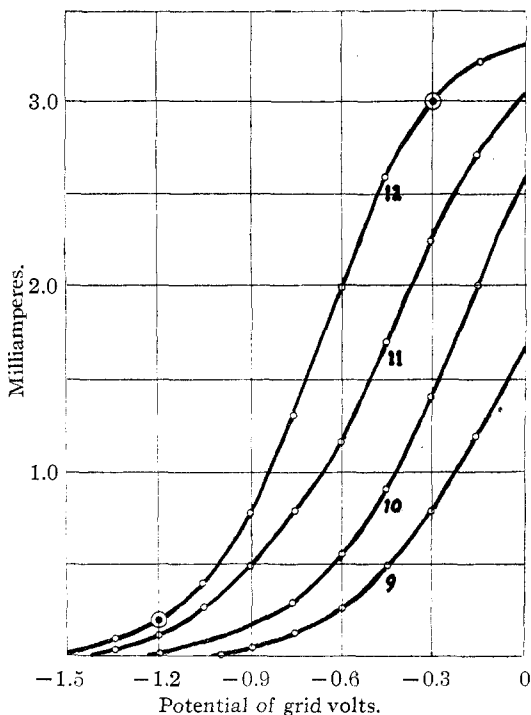

Fig. 6.— E_1 battery = 68 volts; E_2 battery = 47 volts.

Curve	E_3 battery volts	Filament current amps.
9	47	0.18
10	47	0.19
11	49	0.19
12	49	0.20

that the voltages of the batteries do not change, and the filament current is kept constant. It is advisable to check the apparatus occasionally against a known potential, however, to guard against error; this can be very conveniently done by using a telephone switch, which throws the grid of the first

⁴ A filament current of more than 0.18 to 0.20 ampere (for three tubes), or a voltage across the filament terminals exceeding 3.0 volts, is very harmful to the tubes, and will materially shorten their lives.

tube either into a circuit consisting of a 3- or 4-volt battery, potentiometer and voltmeter, or into a circuit whose unknown voltage is to be measured.

The milliammeter may itself be used as a voltmeter, if desired, by the use of another telephone switch, which adds sufficient resistance (about 700 ohms) to the meter to make a total of 1000 ohms; the meter will now read directly 0-3 volts instead of 0-3 milliamperes. Used as a voltmeter in this way, the same meter can be employed not only in checking the calibration, but also in regulating the filament voltage to a suitable value. A complete outfit of this type is shown in Fig. 8. The left hand switch, when in the "up" position, puts the meter into the plate circuit of the last vacuum tube; in the middle position the meter is used as a voltmeter in the potentiometer circuit; while in the "down" position the meter indicates the filament potential. The right-hand switch, in the "up" position, connects the unknown potential X to the grid of the first vacuum tube; in the middle position connects the grid circuit to the known potential, adjustable by the potentiometer; and in the "down" position transfers the battery V directly to the terminals V_2 , where it may be used for any purpose desired. The complete circuit for this arrangement is shown in Fig. 7, the dotted lines indicating the position of the switches when in the middle position.

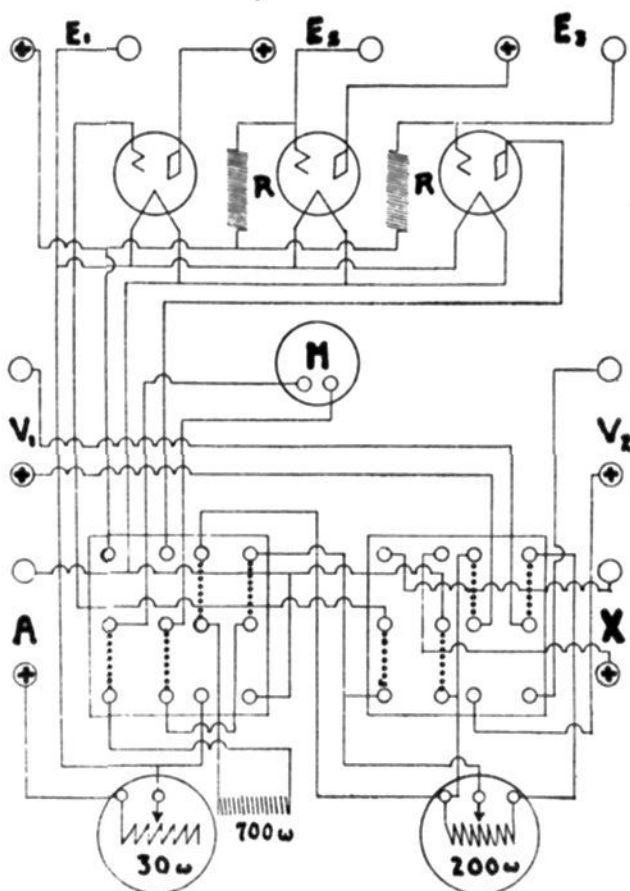

Fig. 7.



Fig. 8.

This apparatus, although developed for use in electrotitration, is by no means limited to this field. By suitable adjustment of the batteries the meter may be made to change from zero to its full scale reading when the unknown grid potential changes from about three volts to zero, or a change of half a volt or more anywhere within this range may be made to produce the same effect. It will thus be found most useful in investigating electrode potentials and overvoltages in connec-

tion with electrolytic processes of all kinds. Under conditions where the potentials to be measured are temporary or unsteady in nature this apparatus will be found particularly useful because of its continuous and direct-reading features.

Summary

A device is described which, by making use of the three-electrode vacuum tube as a voltmeter, and as a direct current amplifier, serves to indicate upon the scale of a milliammeter the potential between any two electrodes ordinarily used in electrochemical work. This device does not draw an appreciable current from the source to be measured, and is continuous and automatic in its operation. It is particularly adapted to use in electro-titration.

STATE COLLEGE, PENNSYLVANIA

[CONTRIBUTION FROM THE CHEMICAL LABORATORY OF THE UNIVERSITY OF ILLINOIS]

THE VAPOR PRESSURE OF SODIUM

BY WORTH H. RODEBUSH AND THOMAS DEVRIES

RECEIVED MAY 22, 1925

PUBLISHED OCTOBER 6, 1925

While it is probably true that the vapor-pressure equation for a metal can be set up from a single measurement (for example, of the boiling point) and the quantum theory of monatomic gases,^{1,2,3,4} the extrapolation necessary is likely to involve considerable error. The validity of the simple equation for the entropy of monatomic gases has even been questioned by Simon⁵ and while the authors believe Simon to be in error, actual measurements of vapor pressure are far more satisfactory than hypothetical calculations.

In the case of sodium, existing data are especially unsatisfactory. Gebhardt⁶ determined the vapor pressure of sodium by the boiling-point method, but his results do not agree with those of Haber and Zisch⁷ determined by a dynamic method. Gebhardt's values are for temperatures 40–50° lower than those given by Haber and Zisch, who determined only four pressures between 470° and 570°. Hackspill⁸ determined four irregular points between 350° and 400° by a method that can be questioned.

¹ Tetrode, *Ann. Physik*, **38**, 434 (1912).

² Einstein, *Ber. Berl. Akad.*, **261** (1924).

³ Millar, *This Journal*, **45**, 2323 (1923).

⁴ Egerton, *J. Chem. Soc.*, **123**, 3204 (1923).

⁵ Simon, *Z. physik. Chem.*, **110**, 572 (1924).

⁶ Gebhardt, *Dissertation*, Erlangen, 1903. His data are also published in the article by Kroner, *Ann. Physik*, **40**, 483 (1913).

⁷ Haber and Zisch, *Z. Physik*, **9**, 325 (1922).

⁸ Hackspill, *Compt. rend.*, **154**, 877 (1912).